

DESCRIPTION: AISI 316 equivalent body and disc, high performance lugged type butterfly valve with PTFE sealing. Double offset free stem with standardized pattern for actuator mounting.

APPLICATION: Start/stop and throttling: Water, oils, wide range chemicals etc. Used as e.g. cargo valve.

STANDARD & DESIGN:

Design Code: EN 593t
 Inspection Std.: EN 12266-1
 End Std.: EN 1092-1
 Face to Face Std.: EN 558
 Flanges drilled: PN16 (DN50-DN600)
 Top Flange: ISO 5211 (DN50-DN600)
 Pressure rating: PN16 (DN50-DN600)

VARIATIONS: Metal to metal seat.
 Metal + PTFE seat as fire safe.
 Various actuators and gearboxes.
 Other dimensions and materials on request.

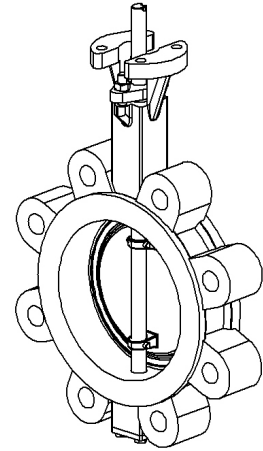

No	Part	Material	Code
1	Body	Stainless Steel	CF8M
2	Disc	Stainless Steel	CF8M
3	Seat	PTFE	-
4	Retainer	Stainless Steel	SUS 316L
5	Stem	Stainless Steel	SUS 316L
6	Taper Pin	Stainless Steel	SUS 316L
7	Upper Bush	316 SS+Graphite	-
8	Lower Bush	316 SS+Graphite	-
9	Gland Ring	Stainless Steel	SUS 304
10	Packing	PTFE	-
11	Gland Flange	Stainless Steel	SUS 304
12	Stud Bolt/SW	Stainless Steel	SUS 304
13	Hex Nut	Stainless Steel	SUS 304
14	Gasket	PTFE	-
15	End Cover	Stainless Steel	SUS 304
16	Hex Bolt/SW	Stainless Steel	SUS 304
17	Wrench Bolt	Stainless Steel	SUS 304

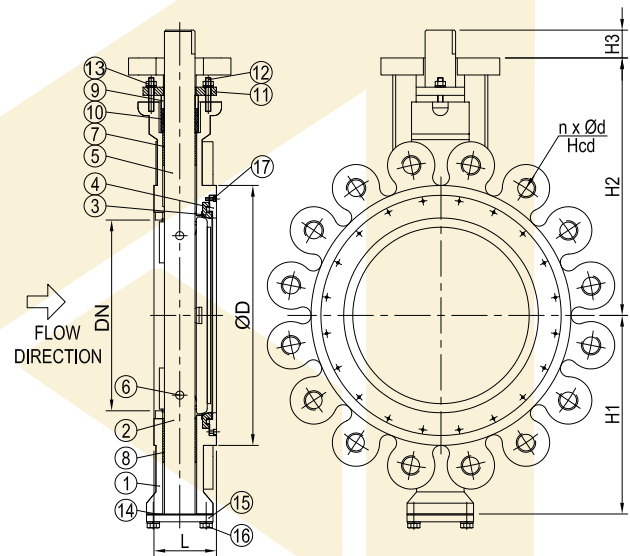

DN	n x ød	Hcd	øD	L	H1	H2	H3	Kg
50	4xM16	125	100	43	70	142.5	41	5.5
65	4xM16	145	108	46	76	150	41	7.3
80	8xM16	160	121	46	99	168.5	41	9.1
100	8xM16	180	155	52	110	180	41	11.1
125	8xM16	210	180	56	135	193	41	13.7
150	8xM20	240	205	56	140	195	41	17.5
200	12xM20	295	266	60	176	240	41	28.5
250	12xM24	355	321	70	215	302	41	43.5
300	12xM24	410	367	78	240	325	41	57.2
350	16xM24	470	430	78	263	350	41	89.2
400	16xM27	525	470	102	292	412	55	120.8
450	20xM27	585	534	114	320	440	55	164.9
500	20xM30	650	610	127	370	505	55	215.8
600	20xM33	770	692	154	410	530	55	339.0